

**DESCRIPTION**

The solenoid valves series "W" can be directly actuated, servo-assisted or with mixed actuation. These solenoid valves, produced in the 2/2 N.C. pneumatic function, are used in several industrial fields, thanks to their compatibility with a large range of fluids.

**TECHNICAL DATA**

Operating pressure	(See tables below)
Working temperature range	NBR -10 ÷ +90 °C EPDM < +140 °C FPM -10 ÷ +130 °C
Fluid	(See technical information)
Port size	G 1/8 ÷ G 2
Coils	WE3A - see on page 2.93 WE2A - see on page 2.93 WE5A - see on page 2.93
Electric connectors	USR102/N9 - see chapter Connectors on page 2.15 ULR1B - see chapter Connectors on page 2.15

**MATERIALS**

Body	Brass
Sleeve	Brass
Moving core	Stainless steel
Springs	Stainless steel
Seals	NBR EPDM FPM

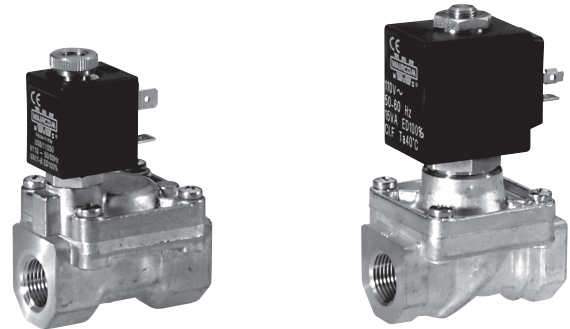

2

**TECHNICAL INFORMATION**

Seal type	Duty field
NBR	Water max. 70 °C, air max. 90 °C, mineral oils and derivatives - hydrocarbons (methane, ethane, propane, butane, kerosene and gas oil)
EPDM	Hot water and steam max. 140 °C, detergents, solutions of sodium and potassium, hydraulic fluids and polar solvents (not to be used with mineral oils and grease)
FPM (Viton®)	For general purpose max. 130 °C

**Calculation of the flow rate**

For liquids	$Q = K_v \sqrt{\frac{\Delta p}{\rho}}$
For gases	$Q_n = 26 K_v \sqrt{\Delta p P}$
Kv =	Flow coefficient
Q = m³/h	Flow rate
Qn = m³/h	Normal flow rate (20 °C and 760 mm Hg)
P = bar	Absolute downstream pressure
Δp = bar	Pressure drop (differential pressure between the upstream and downstream pressure)
ρ = Kg/dm³	Specific gravity (ratio of density of the substance to the density of water at 4°C)

**2 PORT G 1/8 - DIRECTLY ACTUATED**

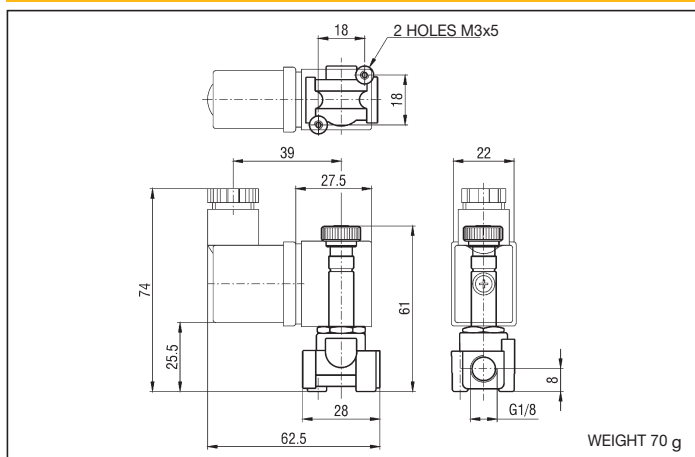

Symbol	Function	Differential pressure (bar)		Kv	Nominal orifice (mm)	Port size	TYPE**	
		MIN.	MAX.					
	2/2 N.C.	0	25	25	0,04	1,2	W 105 1 * E3A	
		0	16	16	0,06	1,5	G 1/8	W 105 2 * E3A
		0	12	10	0,09	2	G 1/8	W 105 3 * E3A
		0	8	5,5	0,14	2,5	G 1/8	W 105 4 * E3A
		0	5	2	0,19	3,1	G 1/8	W 105 5 * E3A

\* SPECIFY THE SEALING TYPE: B = NBR; V = FPM; E = EPDM

\*\* THE TYPES OF THE SOLENOID VALVES DO NOT INCLUDE COILS (SEE "WE3A" ON PAGE 2.93)

2

## 2 PORT G 1/8 - G 1/4 DIRECTLY ACTUATED

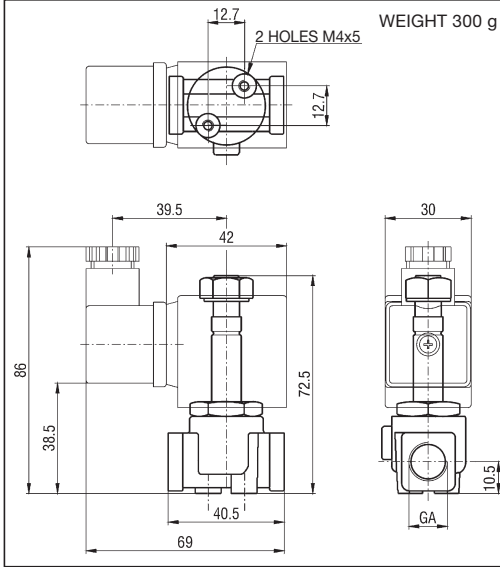

Symbol	Function	Differential pressure (bar)		Kv	Nominal orifice (mm)	Port size (GA)	TYPE**	
		MIN.	MAX.					
			AC					DC
	2/2 N.C.	0	30	26	0,07	1,5	G 1/8	W106 1 * E2A
		0	22	20	0,1	2	G 1/8	W106 2 * E2A
		0	16	14	0,15	2,5	G 1/8	W 106 3 * E2A
		0	10	8	0,32	3,5	G 1/8	W 106 4 * E2A
		0	30	26	0,07	1,5	G 1/4	W 106 5 * E2A
		0	22	20	0,1	2	G 1/4	W 106 6 * E2A
		0	16	14	0,15	2,5	G 1/4	W 106 7 * E2A
		0	10	8	0,32	3,5	G 1/4	W 106 8 * E2A
		0	6,5	3,5	0,41	4,5	G 1/4	W 106 9 * E2A
		0	4	1,8	0,47	5,2	G 1/4	W 106 10 * E2A
		0	-	1	0,64	6,4	G 1/4	W 106 11 * E2A

\* SPECIFY THE SEALING TYPE: B = NBR; V = FPM; E = EPDM

\*\* THE TYPES OF THE SOLENOID VALVES DO NOT INCLUDE COILS (SEE "WE2A" ON PAGE 2.93)

## 2 PORT G 3/8 - G 2 SERVO ASSISTED

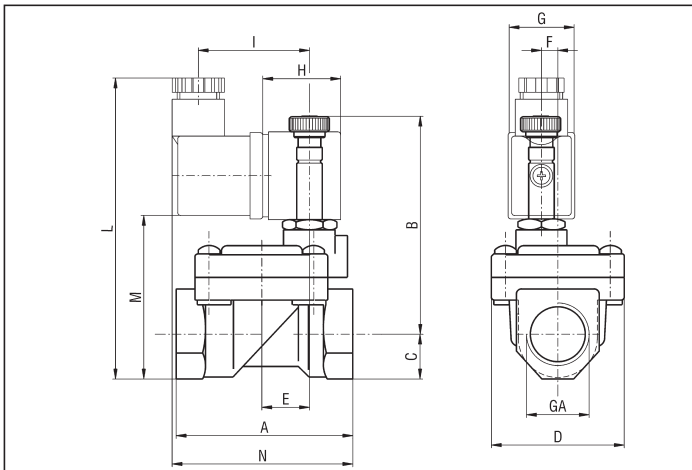

Symbol	Function	Differential pressure (bar)		Kv	Nominal orifice (mm)	Port size (GA)	TYPE**	
		MIN.	MAX.					
			AC					DC
	2/2 N.C.	0,15	15	15	2	12	G 3/8	W 107 1 * E3A
		0,15	15	15	2,2	12	G 1/2	W 107 2 * E3A
		0,15	13	13	5,2	18	G 3/4	W 107 3 * E3A
		0,15	10	10	10,2	24	G 1	W 107 4 * E3A
		0,15	10	10	18	37	G 1 1/4	W 107 5 * E2A
		0,15	10	10	21	37	G 1 1/2	W 107 6 * E2A
		0,15	10	10	36	50	G 2	W 107 7 * E2A

\* SPECIFY THE SEALING TYPE: B = NBR, V = FPM, E = EPDM

\*\* THE TYPES OF THE SOLENOID VALVES DO NOT INCLUDE COILS (SEE "WE2A" AND "WE3A" ON PAGE 2.93) THAT HAVE PREFERABLY TO BE MOUNTED TOWARD THE HIGH

GA	A	B	C	D	E	F	G	H	I	L	M	N	WEIGHT (g)
G 3/8	60	70	14	45	16	6	22	27,5	39	102	53,5	62,5	450
G 1/2	60	70	14	45	16	6	22	27,5	39	102	53,5	62,5	450
G 3/4	75	74	18	55	20	8,5	22	27,5	39	108	59,5	66	660
G 1	96	85	20	72	32	-	22	27,5	39	120	71,5	64,5	1200
G 1 1/4	144	107	28	102	45	-	30	42	39,5	128	79,5	75,5	3200
G 1 1/2	144	107	28	102	45	-	30	42	39,5	128	79,5	75,5	2900
G 2	152	116,5	35	119	48	-	30	42	39,5	159	110,5	76,5	4500

## 2 PORT G 3/8 - G 1 WITH MIXED ACTUATION

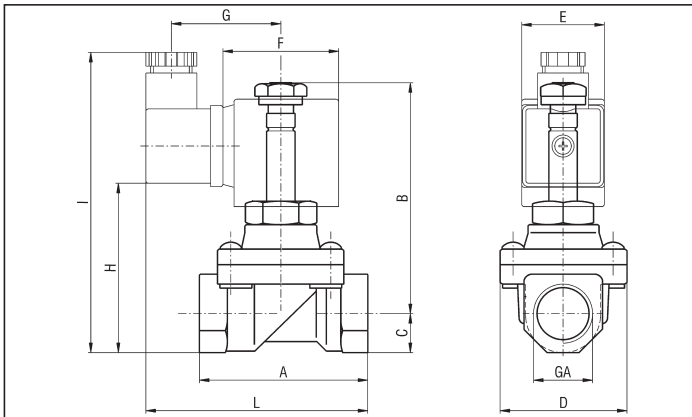

GA	A	B	C	D	E	E	F	F
					WE2A	WE5A	WE2A	WE5A
G 3/8	59	83	14	45	30	36	42	47,5
G 1/2	59	83	14	45	30	36	42	47,5
G 3/4	79	90	18	55	-	36	-	47,5
G 1	96	101	20	72	-	36	-	47,5

G	G	H	H	I	I	L	L	WEIGHT
WE2A	WE5A	WE2A	WE5A	WE2A	WE5A	WE2A	WE5A	(g)
39,5	42,5	58,5	58	106	105,5	79	82	580
39,5	42,5	58,5	58	106	105,5	79	82	530
-	42,5	-	69	-	116,5	-	89,5	750
-	42,5	-	82	-	129,5	-	100	1200

Symbol	Function	Differential pressure (bar)			Kv	Nominal orifice (mm)	Port size (GA)	TYPE**
		MIN.	MAX.					
			AC	DC				
	2/2 N.C.	0	10	-	2	12	G 3/8	W 108 1 * E2A
		0	10	-	2,2	12	G 1/2	W 108 2 * E2A
		0	12	10	2	12	G 3/8	W 108 1 * E5A
		0	12	10	2,2	12	G 1/2	W 108 2 * E5A
		0	9	-	4,5	18	G 3/4	W 108 3 * E5A
		0	7	-	8,5	24	G 1	W 108 4 * E5A

\* SPECIFY THE SEALING TYPE: B = NBR; V = FPM; E = EPDM

\*\* THE TYPES OF THE SOLENOID VALVES DO NOT INCLUDE COILS (SEE "WE2A" AND "WE3A") THAT HAVE PREFERABLY TO BE MOUNTED TOWARD THE HIGH

### COIL TYPE WE3A

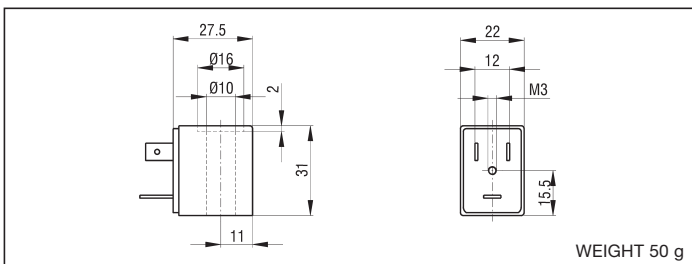

Power consumption	DC: 5,5 W AC: 11 VA (inrush)
-------------------	---------------------------------

DESCRIPTION	TYPE
COIL 22 mm 24 V DC	WE3A/02400
COIL 22 mm 24 V AC	WE3A/02450-60
COIL 22 mm 110 V AC	WE3A/11050-60
COIL 22 mm 220 V AC	WE3A/22050-60

ELECTRIC CONNECTOR "USR 102/N9" (SEE ON PAGE 2.15)

### COIL TYPE WE2A

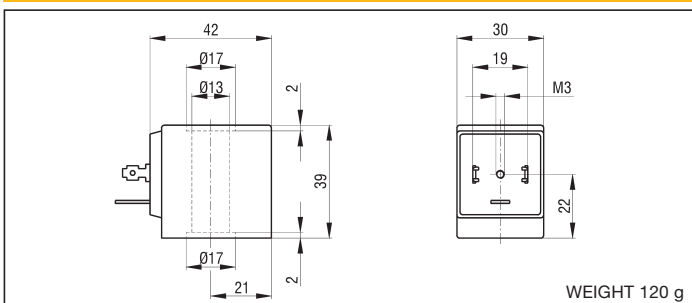

Power consumption	DC: 8 W AC: 20 VA (inrush)
-------------------	-------------------------------

DESCRIPTION	TYPE
COIL 30 mm 24 V DC	WE2A/02400
COIL 30 mm 24 V AC	WE2A/02450-60
COIL 30 mm 110 V AC	WE2A/11050-60
COIL 30 mm 220 V AC	WE2A/22050-60

ELECTRIC CONNECTOR "ULR1B" (SEE ON PAGE 2.15)

### COIL TYPE WE5A

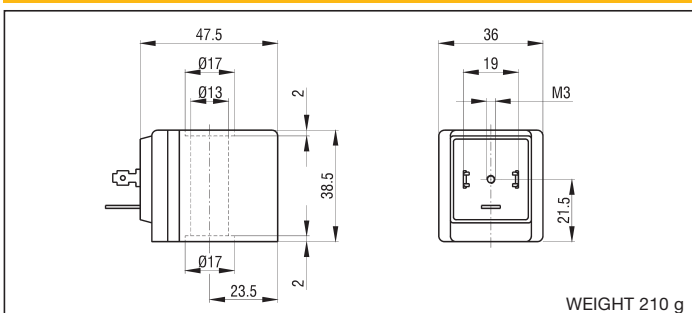

Power consumption	DC: 23 W AC: 40 VA (inrush)
-------------------	--------------------------------

DESCRIPTION	TYPE
COIL 36 mm 24 V DC	WE5A/02400
COIL 36 mm 24 V AC	WE5A/02450-60
COIL 36 mm 110 V AC	WE5A/11050-60
COIL 36 mm 220 V AC	WE5A/22050-60

ELECTRIC CONNECTOR "ULR1B" (SEE ON PAGE 2.15)